

REVISION			
REV.	DESCRIPTON	DATE	APPROVED
-	INITIAL RELEASE	2012/07/31	

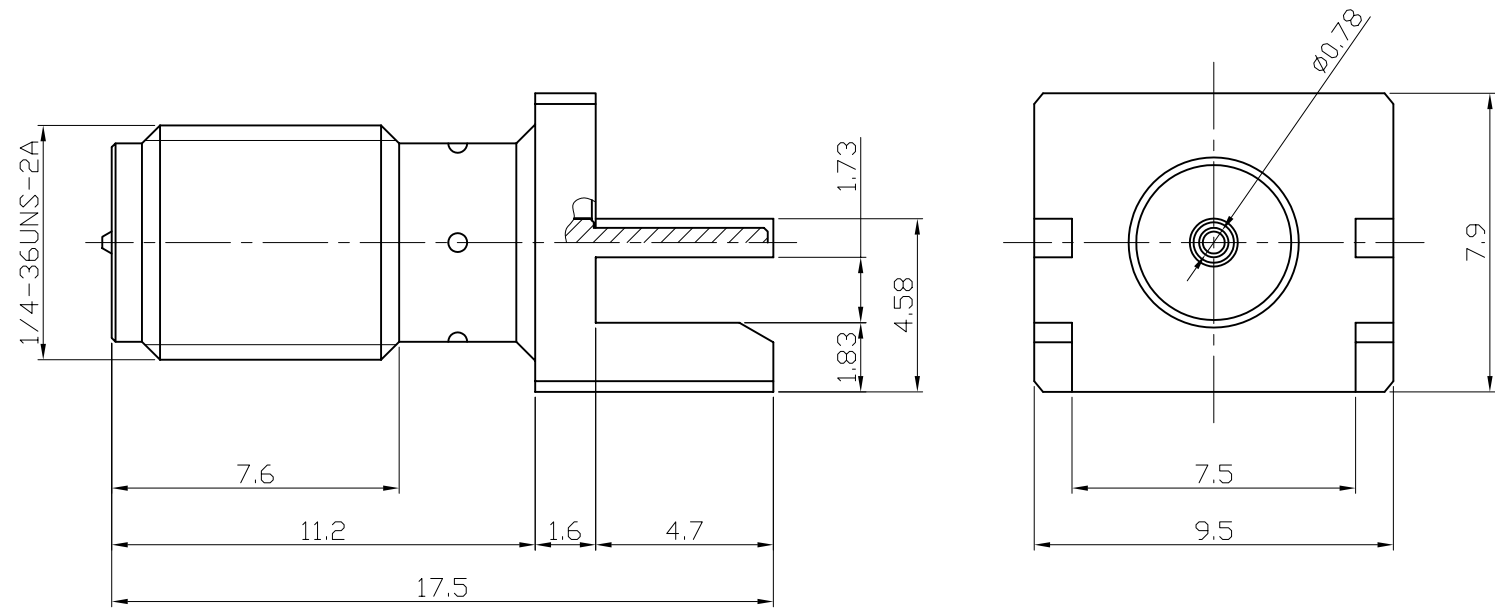

NOTES: FINISH (PLATING THICKNESS IN MICRO-INCHES)
 1. BRASS.
 2. GOLD PL. 4 MIN. OVER NICKEL-PHOSPHORUS ALLOY
 PL. 80 MIN. OVER COPPER PL. 20 MIN.

DIMENSION ARE MILLIMETERS UNLESS OTHERWISE SPECIFIED TOLERANCES (UNIT:MM)						SCALE	REV	UNIT	JYE BAO CO., LTD.		
0.5~5 = ± 0.05 5~10 = ± 0.07 10~20 = ± 0.10 20~30 = ± 0.15 30~ = ± 0.20						5 / 1	-	MM	TAIPEI TAIWAN		
						APPROVED			DATE	TITLE	
						CHECKED			DATE	SMA R/P JACK PCB EDGE MOUNT	
						DRAWING			DATE	DRAWING NO.	
						Albert			SMA9433-0000		

NO.	DESCRIPTION	MATERIAL	FINISH	Q'TY	PART NO.
3	CONTACT PIN	NOTE 1	NOTE 2	1	SMA9433-3/NM
2	INSULATOR	TEFLON		1	SMA8433-2
1	BODY	NOTE 1	NOTE 2	1	SMA8433-1/NM