

TNC8105-0058

TNC Jack Crimp For Bulkhead 50Ω

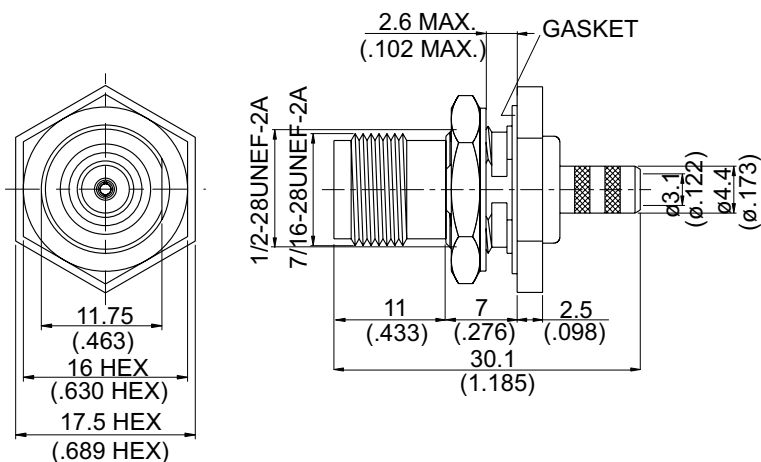

MOUNTING HOLE :

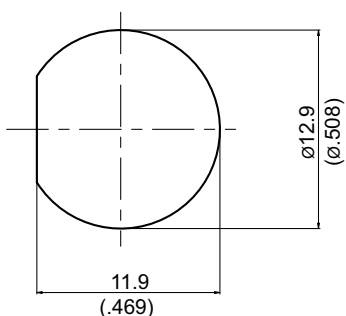

Parts	Material	Plating (Micro-inch)
Ferrule	Brass	Tin-Zinc-Copper-Alloy 100 Over Copper 50
Center Pin	Phosphor Bronze	Gold 3 Over Nickel 50 Over Copper 50
Hex Nut	Brass	Tin-Zinc-Copper-Alloy 100 Over Copper 50
Washer	Brass	Tin-Zinc-Copper-Alloy 100 Over Copper 50
Gasket	Silicon	
Barrel	Brass	Tin-Zinc-Copper-Alloy 100 Over Copper 50
Insulator	Teflon	
Body	Brass	Tin-Zinc-Copper-Alloy 100 Over Copper 50

Weight: 17.18 g

Suitable Cables: RG58, JBY195

This part number complies with RoHS.

Notice: JYEBAO reserves the right to make modifications deemed appropriate.

CABLE ASSEMBLY INSTRUCTION

TNC8105-0058

JYE BAO CO., LTD.

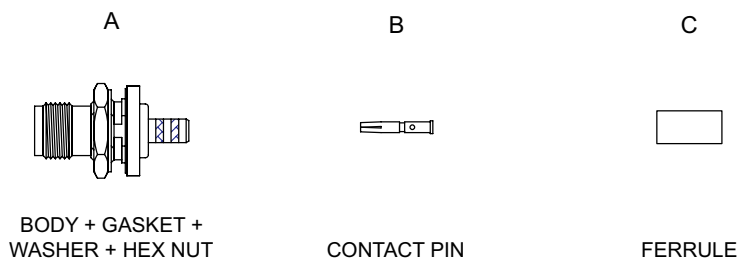
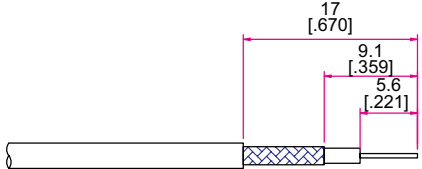
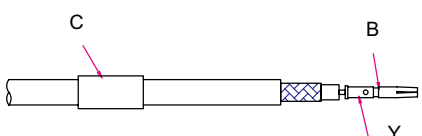
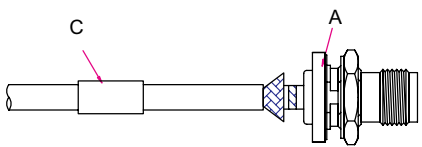
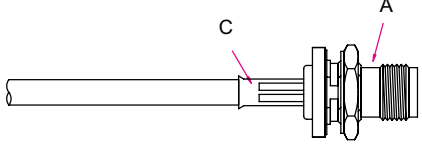

DIAGRAM	ASSEMBLY INSTRUCTION
	Step 1: STRIP AS SHOWN .
	Step 2: SLIDE FERRULE " C " OVER CABLE. Step 3: PUT PIN " B " ON CENTER CONDUCTOR AND SOLDER IN " Y ".
	Step 4: LOOSEN BRAIDING AND SLIDE CONNECTOR " A " IN PLACE.
	Step 5: SLIDE FERRULE " C " TOWARDS THE CONNECTOR " A " AND CRIMP.

This part number complies with RoHS.

Notice: JYEBAO reserves the right to make modifications deemed appropriate.