

Dual-frequency Mobile GlassFix® Antenna for the 2 m and 70 cm Amateur Bands

DESCRIPTION

- Dual-frequency mobile antenna for the 2 m and 70 cm amateur bands using the GlassFix® mounting principle.
- Mounting on car window glass – no holes required

NOTE

GF antennas are not suitable for car models with windows that have heat reflective coating.

- Makes it possible to:
 - operate 2 m and 70 cm transceivers alternately on the same antenna
 - operate two transceivers (2 m and 70 cm) at the same time using a diplexer (type DIPX 225/330 – to be ordered separately).
- Double-adhesion procedure ensures fast and reliable fixing.
- Internal matching unit feeds external antenna through window glass.
- Shortened half-wave (2 m) / half-wave colinear design (70 cm) – no ground-plane required.
- High positioning gives performance equal to conventionally mounted car roof antenna.
- FME FastCabling system (cable to be ordered separately).
- Simple tuning procedure by means of two tuning screws on matching unit.
- Easy removable whip for car wash.
- Swivel joint for 180° angle adjustment.
- If removal of antenna installation is necessary, a quick dismantling procedure leaves no trace of the installation.



ORDERING

Type	Product No.
GF 2/70	130000706

SPECIFICATIONS

Electrical	
Model	GF 2/70
Frequency	144 - 146 MHz
Antenna Type	Dual-frequency mobile GlassFix® antenna
Polarisation	Vertical
Impedance	50 Ω
Maximum Input Power	2 m: 20 W 70 cm: 20 W discontinuous
Bandwidth	2 m: 3 MHz 70 cm: 6 MHz @ SWR = 2.0
Gain (EIA RS-329-1)	2 m: equal to shortened roof-mount antenna 70 cm: 1 dB (acc. to EIA RS-329-1)
Mechanical	
Materials	Whip: Stainless steel and brass, black-chromed Mount and indoor unit: Weather- and shockproof plastics Corrosion-safe and corrosion-protected metals
Cable	FME-cable to be ordered separately
Colour	Black
Height	78 mm / 3.07 in.
Weight	0.125 kg / 0.28 lb
Mounting	On car windows with silicone glue (52 mm x 47 mm obstruction-free mounting area required)
Glass Thickness	2.5 - 7 mm / 0.10 - 0.28 in.

ADDITIONAL DATA

FME-SYSTEM ACCESSORIES

FME-CABLES	
TYPE	LENGTH
1 m FME	1 m
2 m FME	2 m
3 m FME	3 m
4 m FME	4 m
5 m FME	5 m
6 m FME	6 m
4 m FME-white	4 m white
6 m FME-white	6 m white
12 m FME-white	12 m white
18 m FME-white	18 m white

FME-CONNECTORS	
TYPE	CONNECTOR
FME-FME	FME-FME
FME-P	Prolongation
FME-N	N
FME-FSMA	FSMA
FME-BNC	BNC
FME-TNC	TNC
FME-UHF	UHF
FME-MUHF	Mini-UHF
FME-EMUHF	Elbow-MUHF
FME-EBNC	Elbow-BNC
FME-ETNC	Elbow-TNC
FME-SMA	SMA

For further information about other types of FME-cables and FME-connectors, please compare the cable and connector data sheets under accessories in our catalogue.

ASSEMBLY DETAILS

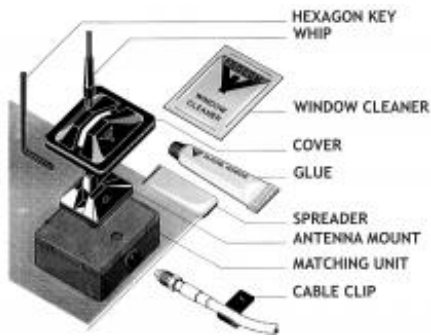

OPERATION USING A DIPLEXER

In case of operating two transceivers on one antenna at the same time, a diplexer, type DIPX 225/330 is necessary to complete the system. The tasks of the diplexer are to protect the two receiver inputs from being destroyed by the transmitter in the contrary band, and to ensure a low-loss path between the transceiver and the antenna, which is not loaded by the other branch. For further details please see the separate data sheet on the DIPX 225/330. The diplexer fully covers both bands and, consequently, tuning to specific frequencies is not required.

COUPLING DIAGRAM

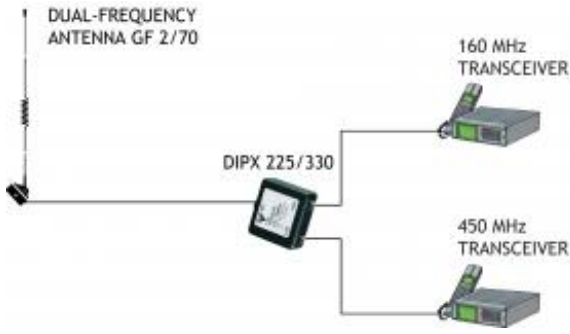

1. BEFORE INSTALLATION

- > When selecting mounting location take into consideration: positions of back view mirror, wiper blade paths and defogger wires (when mounting on rear window). The driver's view should not be obstructed.
- > Max. allowed curvature of the glass surface on the mounting spot is 2 mm deflection per 100 mm length.
- > Environmental- and car temperature must be above 15° C at installation, and surfaces to be glued must be dry and clean.

2. INSTALLATION

<p>1. Clean both sides of the windscreen, where the antenna mount and the matching unit are to be fitted, and then remove the protective foil from the antenna mount.</p>	<p>2. Fit mount to screen and press firmly. Apply glue along the edge between mount and glass.</p>
<p>3. Apply glue to the cover.</p>	<p>4. Fit the cover and press down firmly. The antenna whip can now be fitted.</p>
<p>5. Remove the protective foil on the matching unit.</p>	<p>6. Fit matching unit by pressing it firmly into position. Secure cable using clips provided.</p>

3. AFTER INSTALLATION

- > Allow the silicone gluings to dry off 2 hours at a temperature above 15° C. To ensure full strength of the glue, it is recommended to keep the whip off the mount for 24 hours.

4. TUNING INSTRUCTIONS

- > Insert a forward/reflection-type wattmeter between the transmitter and the antenna.
- > Key the transmitter on the 2 m band and observe the forward and the reflected power.
- > Adjust the tuning screw marked "2 m" on the matching unit until minimum returned power is obtained.
- > Repeat steps 2. and 3. with the transmitter on the 70 cm band and using the tuning screw marked "70 cm".

- Check that the reflected power is still minimum at the 2 m band. Fine-tune using the "2 m" tuning screw if necessary.

REINSTALLATION KIT

A reinstallation kit including all necessary parts for transfer of the antenna to another vehicle is available under order No. »GF-RK«.

WARNING

SAFETY PRECAUTIONS

Antennas mounted on the windscreen may cause relatively high field strengths in the passenger cabin and near the dashboard.

- To prevent health hazard due to RF radiation, persons must not be closer than 30 cm to the antenna whip (transmitter output power to the matching unit: 20 W). (DIN 57 848).
- The RF signals at the dashboard may cause interference in the car's electronic equipment such as broadcast radio, computer automatics, braking systems, electronic ignition, relays etc. Some cars are more susceptible to disturbances than others.
It is the responsibility of the installer to carry out a thorough check of the proper functioning under any conditions of such circuits before finishing installation.

The enclosed silicone adhesive contains acetic acid and fungicides. Keep out of reach of children and dispose properly.

